



Combidryer WS190

Air dryer heat exchangers series



General

Alfa Laval supports the compressed air industry with the latest developments for refrigerated air dryers. Going further with brazed heat exchanger technology and integrated valves. The Alfa Laval WS190 takes the customer value to a higher system solution.

Alfa Laval Combi Dryer WS190 optimize the performance of your process with an optimised customer system solution. WS190 is a brazed heat exchanger with additional added values. WS190 has both the air to air heat recovery and the air to refrigerant connected with integrated heat recovery by pass, to avoid any unnecessary extra piping.

To solve an easy installation all refrigerant connections are on one side, air and drain is one the other.

Included inside of the Combi Dryer WS190 is a water separator function with a high efficiency. The WS190 series is designed for a high thermal performance and a low pressure drop.

The capacity range covers from 20-90 Nm³/h. (12-50 scfm).

Features and advantages

- Added customer value with integrated water separator. Efficient water separator function inside of the air dryer heat exchanger.
- Very low pressure drop over heat exchanger and separator of maximum 12 kPa (0.8 psi), at nominal flow rates. Requires a minimum of power usage.
- Excellent thermal performance which separates the water at the coldest point and gives a high separation efficiency of minimum 98%.
- Two combined heat exchangers, consisting of both the air to air heat recovery and air to refrigerant heat exchanger. Integrated connection with heat recovery that require no additional piping.
- Convenient connection locations. For easy mounting all refrigerant connections on one side, air and water drain on the opposite.
- Stainless steel for high reliability and long lifetime.
- Compact size. The corrugated compressed air plates with included customer features as water separator and heat recovery reduces significantly the total air dryer size.

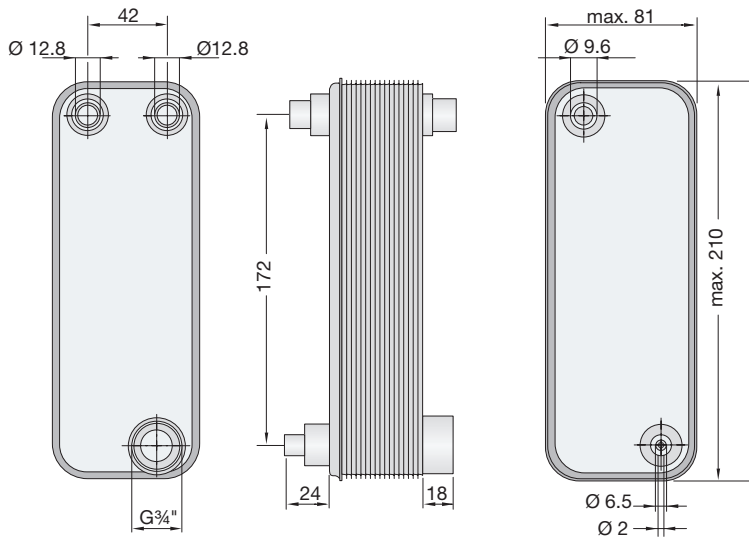

Technical data

Minimum working temperature
-160°C (-256°F)

Maximum working temperature
225°C (437°F)

Design pressure
20 bar (290 psig)

Test pressure
24 bar (348 psig)

Weight kg
 $0.7 + 0.06 \times n$

Thermal design

According to CAGI. Inlet air conditioning of 100°F saturated, 100 psig and outlet PDP of 35°F with less than 1 psi pressure drop.

Model	Nm ³ /h	scfm	Freon connections	Air connections	Drain
WS190-22	24	14	1/4" / 3/8"	1/2"	3/4"
WS190-30	32	19	1/4" / 3/8"	1/2"	3/4"
WS190-34	36	21	1/4" / 3/8"	1/2"	3/4"
WS190-50	52	30	1/4" / 3/8"	1/2"	3/4"
WS190-72	72	42	1/4" / 3/8"	1/2"	3/4"
WS190-86	86	50	1/4" / 3/8"	1/2"	3/4"

Dimensions and weight

	A Dimension (mm)	Weight (kg)
WS190-n	$A = 42 + 2.4 \times n$	$0.7 + 0.06 \times n$

Working principles

The heating surface consists of thin corrugated stainless steel plates that are compressed together to form a plate pack. Channels are formed between the plates and the ports are arranged so the media flows through alternate channels in full counter current flow. Media is directed by a brazed seal enhanced with contact points to contain the media flow pressure.

Convenient location of air in- and outlet on the same side.

Water is separated at the coldest point and then exits through drain.

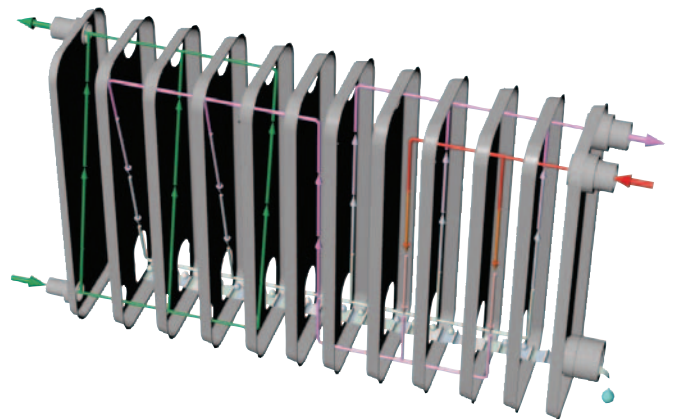

How to contact Alfa Laval

Up-to-date Alfa Laval contact details for all countries are always available on our website at www.alfalaval.com