

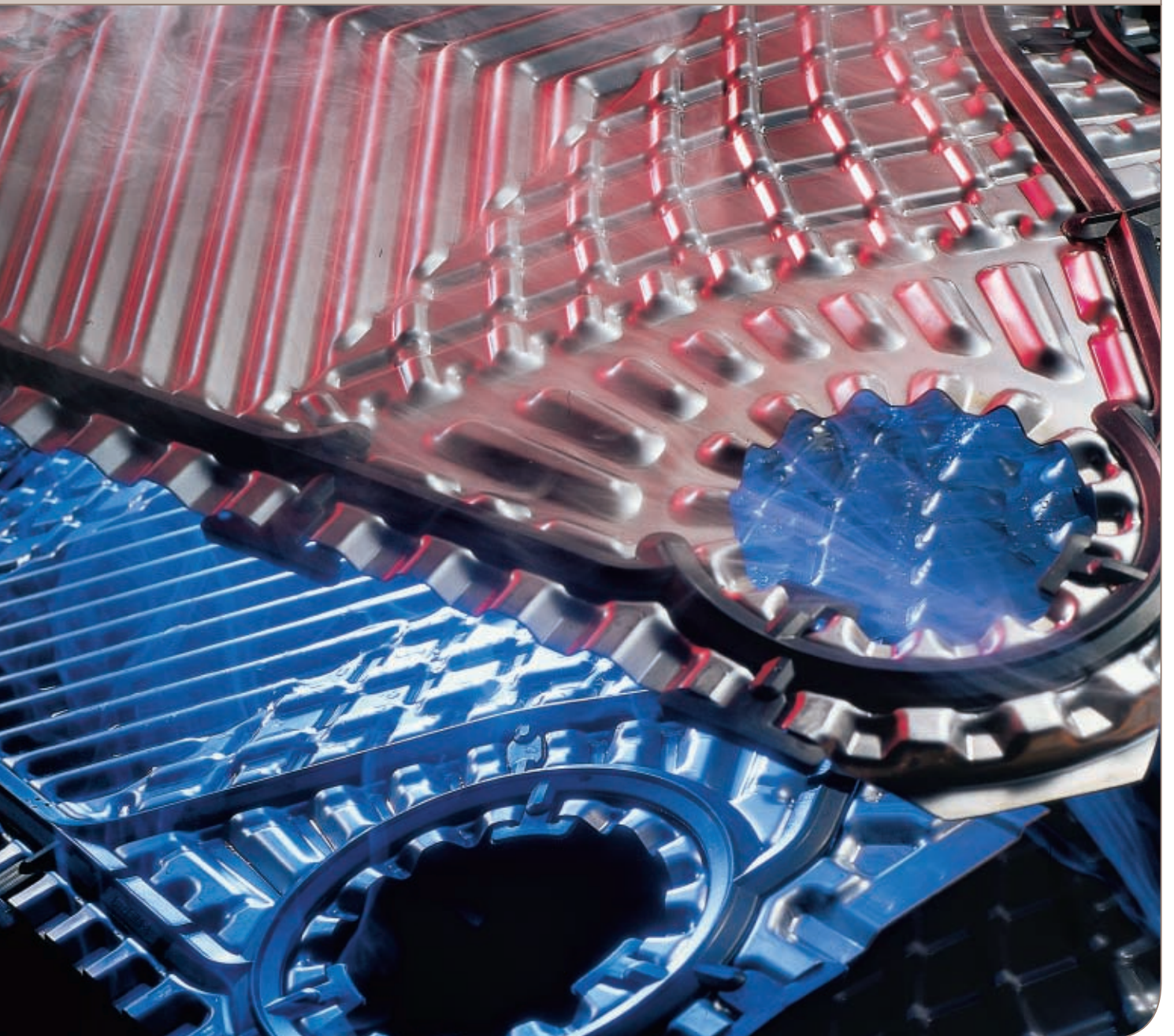

Steam heaters - the new generation

Plate heat exchangers specially designed for steam applications



No other steam heater gives greater all-round economy

The features of the TS-M series provide operational economy and performance unmatched by either shell-and-tube heat exchangers or conventional plate heat exchangers. It's the new generation of steam heaters.

- No flash steam and consequent energy loss.
- Low installation cost
- Rapid maintenance and cleaning.



Alfa Laval has developed a new series of plate heat exchangers specially designed for heating water using industrial steam – the TS-M Series.

The major features of this series are the unique geometry and strength of the stain-less steel plates, special gaskets that tolerate temperatures up to 180° C (356 °F), and the robust heat exchanger frame.

Together, these features provide operational economy and performance unmatched by either shell-

and-tube heat exchangers or conventional plate heat exchangers. The TS-M Series is the new generation of steam heaters.

Together, the design and performance of the TS-M Series add up to greater lifecycle economy when heating water for industrial purposes. The three areas where significant cost savings can be made are:

Savings in energy

- No flash steam and consequent energy loss
- Fine temperature control
- Minimal steam consumption due to minimal condensation temperature

Savings in time

- Easy-to-change capacity
- Minimal scaling
- Rapid maintenance and cleaning

Savings in costs

- Smaller footprint facilitates installation
- No need for a separate condensate subcooler
- No thermal fatigue problems



Outdating shell-and-tubes

Despite their many drawbacks, shell-and-tube heat exchangers (S&Ts) have dominated the steam heater market. Now, with the introduction of the dedicated TSM Series, S&Ts are an outdated solution for most water-heating applications.

The economic and mechanical benefits of TS-M steam heaters make S&Ts a less attractive solution.

The TS-M Series has no rivals

A great advance on conventional PHEs

Optimized plate design

The TS-M Series solves two main problems that occur when conventional plate heat exchangers (PHEs) are used as steam heaters. The first is that when water is heated over a relatively wide temperature difference, e.g. from 10 to 70 °C (50 to 158 °F), the high steam velocity causes erosion and noise problems. The second is that when high water flow rates are used when heating water only a few degrees, the PHE has to be oversized to keep the secondary side (water) pressure drop within reasonable limits.

Both of these drawbacks are now eliminated in the new TS-M Series of PHEs by a unique plate geometry that allows problem-free heating over narrow and wide temperature ranges.

Long-life gaskets

Alfa Laval has developed a new gasket material called Heatseal F™ that tolerates temperatures up to 180 °C (356 °F). This much-improved gasket makes it possible to use the TS-M Series with most industrial steam systems.

More robust construction

Each metallic part of the TS-M Series of PHEs has been improved to withstand the severe conditions found with steam heating.



Way ahead of shell-and-tubes

No thermal fatigue

Cyclic heating and cooling produces thermal fatigue in rigid steam heaters like straight shell-and-tubes. This often

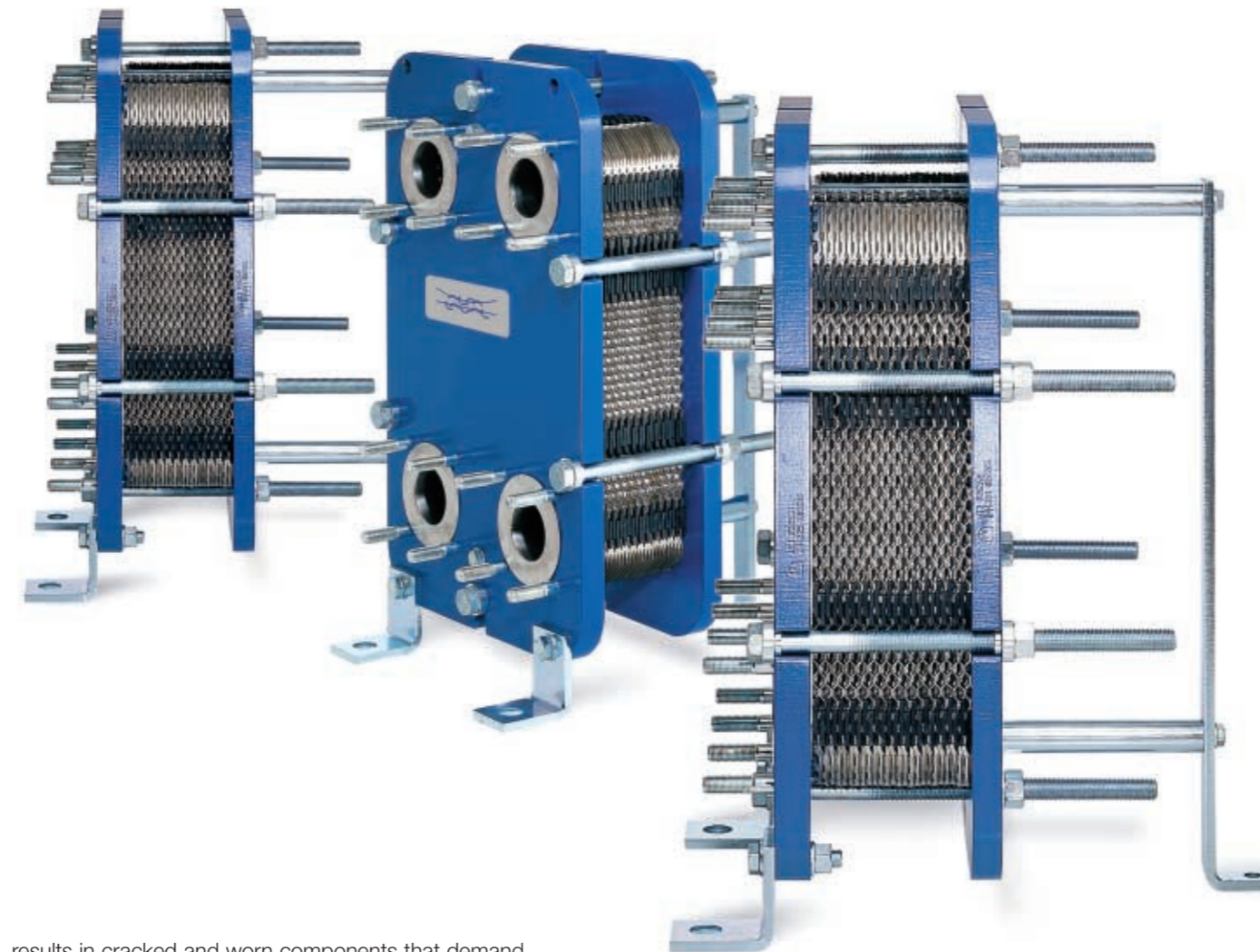

results in cracked and worn components that demand maintenance and repair, thereby causing unwanted system downtime.

The combination of thin plates and flexible gaskets in the TS-M Series prevents thermal fatigue by allowing the units to expand and contract in response to temperature changes.

Fine temperature control

Rapid heat transfer resulting from the small hold-up volume and high surface/volume ratio of the plates enables a fast response to temperature control. The low P x V value may also eliminate the need for regulatory approval or inspection by pressure vessel authorities.

Compact units

Because the design of the TS-M Series is optimized for steam heating, units have a small foot-print compared with shell-and-tube steam heaters. This allows TS-M units to

be readily integrated with existing or new plant equipment.

Competitive price

Plate heat exchangers are a more economic alternative to S&T heat exchangers for typical industrial water-heating applications.

Easy cleaning

Plates are readily removed for cleaning as required. This makes the unit very suitable for heating water for industrial purposes, and heating hard tap water.



Corrosion resistant

The stainless-steel plates tolerate aerated water and other corrosive liquids. Plates made of other materials are also available, such as titanium for resistance to sea water.

Flexibility

The simple addition or removal of plates allows a unit to be easily reconfigured to suit new operating conditions.

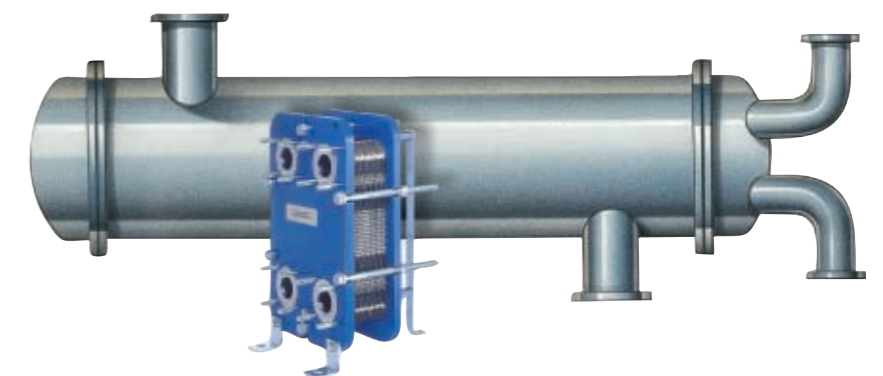

Ideal steam heaters for heating water

The TS-M Series of steam heaters are compact, high-performance units. They allow fine temperature control for accurate operation, maximum heating efficiency and minimum energy costs.

- Compact, high performance units
- Minimum energy costs
- Maximum heating efficiency



- No problems with flash steam
- Fast heating response
- Excellent in packaged solutions

The TS-M Series of steam heaters can be used for a wide range of water-heating applications. They are compact, high-performance units which allow fine temperature control for accurate operation, maximum heating efficiency and minimum energy costs. A correctly designed automatic control system is capable of providing accurate and uniform control under all operating conditions, as well as providing the speed of response required.

Because they are compact, the TS-M steam heaters can be readily integrated with other equipment, often in spaces that are too small for shell-and-tube heat exchangers dimensioned for the same application.

Superior to shell-and-tubes

Lower additional cost when dimensioning for a relatively low condensation temperature

Thanks to the high thermal efficiency of the TS-M heat exchangers, they can be sized to operate at a low condensation temperature at low cost, and little or insignificant amounts

of flash steam are generated. You benefit from:

- no energy loss through ventilating flash steam
- elimination of the need for – and cost of – a separate subcooler or flash steam recovery system

A relatively low condensation temperature also means that the wall temperature on the water side of the TS-M heat exchangers is low enough to hinder surface scaling. This sustains high heat transfer to give lower running costs, less maintenance and higher uptime.

Stalling is not a problem

Unlike S&Ts, the minimal volume between the plates in the TS-M units enables them to continue to function normally during stalling – that is, under vacuum – which leads to a build up of condensate in the heat exchanger. This phenomenon occurs often when heating water to less than 100°C (212 °F). In S&Ts, this leads to big problems with temperature control, and steam implosions that can damage the heat exchanger and associated equipment through water hammer.

Rapid heating

The good temperature control made possible by the small hold-up volume of the TS-M Series enables a fast heating response, e.g. in the instantaneous supply of hot water.

Excellent in packaged solutions

The compactness of the TS-M unit makes it ideal for skid-mounting. Spirax Sarco Ltd, a leading player in the steam industry, has developed a steam heater package based on the TS-M heat exchanger.

A packaged solution incorporating modern condensate removal equipment and an automatic temperature control system provides the rapid response required to give accurate and uniform water heating under all operating conditions.

Typical industries

TS-M units can be used in all industries where steam is the heating medium, including:

- Food and drink
- Chemical processing
- Pharmaceutical
- Manufacturing
- Marine
- HVAC
- Manufacturing



Technical data for TS6 and TS20

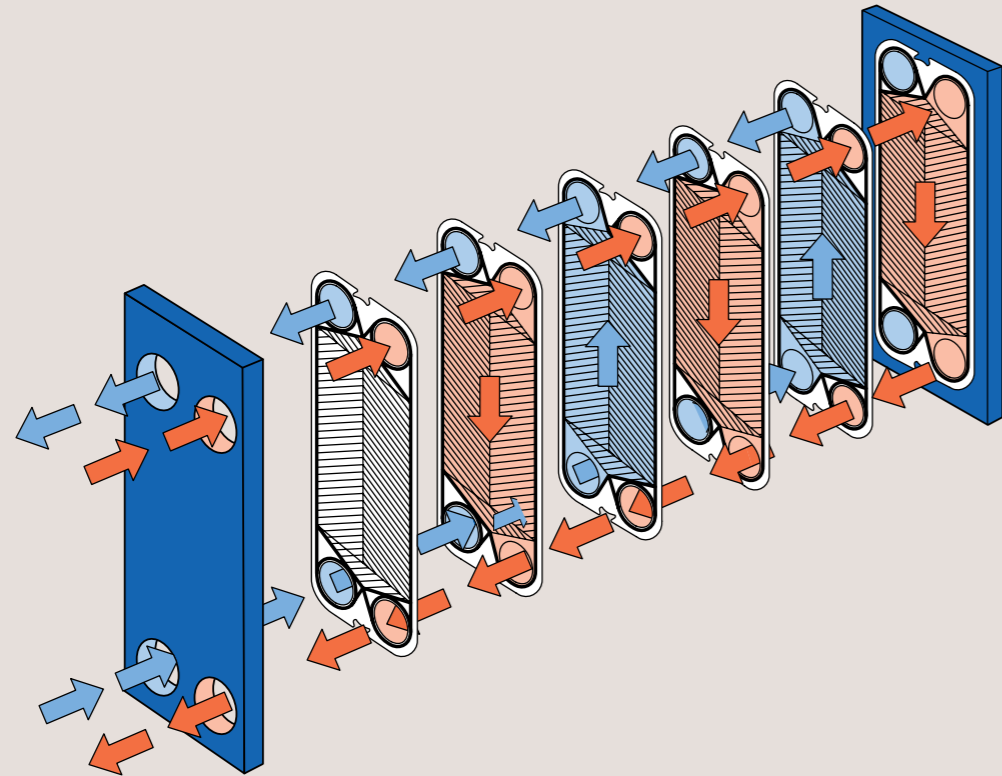

Standard design

The plate heat exchanger consists of a pack of corrugated metal plates with portholes for the passage of the two fluids between which heat transfer will take place.

The plate pack is assembled between a fix frame plate and a movable pressure plate and compressed by tightening bolts. The plates are fitted with a gasket which seals the interplate channel and directs the fluids into alternate channels. The number of plates is determined by the flow rate, physical properties of the fluids, pressure drop and temperature program.

The plate corrugations promote fluid turbulence and support the plates against differential pressure. The plate and the pressure plate are suspended from an upper carrying bar and located by a lower guiding bar, both of which are fixed to a support column. Connections are located in

the frame plate or, if either or both fluids make more than a single pass within the unit, in the frame and pressure plates. Plates can be obtained in all pressable materials. Gaskets are available in a wide range of elastomers.

Working principle

Channels are formed between the plates and corner ports are arranged so that the two media flow through alternate channels. The heat is transferred through the thin plate between the channels, and complete counter current flow is created for highest possible efficiency. No intermixing of the media or leakage to the surroundings will take place as gaskets around the edges of the plates seal the unit. The corrugation of the plates provides a suitable passage between the plates, support of each plate against the adjacent one and a strong turbulence resulting in maximum heat transfer efficiency.

TS6

Applications

General heating and cooling duties. Heating by means of steam.

Liquid flow rate

Up to 50 kg/s (depends on media, permitted pressure drop and temperature program).

Water heating by steam

Up to 1500 kW at a steam condensation temperature of 120 °C
Up to 1800 kW at a steam condensation temperature of 150 °C

Plate types

TS6-M plates.

Frame types

FM, FG and FD.

Standard materials

Frame plate:
Mild steel, epoxy painted.

Nozzles:

Carbon steel
Metal lined: Stainless steel, Titanium

Plates:

Stainless steel AISI 316 or Titanium

Gaskets:

Nitrile, EPDM or HeatSeal F™

Connections

FM	-	Size 65 mm	DIN 2501 PN10
FG	-	Size 65 mm	DIN 2501 PN16
FG	- (ASME)	Size 3"	ANSI 150
FD	-	Size 65 mm	DIN 2501 PN25



Maximum working pressure

FM	-	1.0 MPa over pressure
FG	-	1.6 MPa over pressure
FG	- (ASME)	150 Psig
FD	-	2.5 MPa over pressure
FD	- (ASME)	300 Psig

Maximum heat transfer surface

12.9 m² (140 sq. ft)

Particulars required for quotation

- Flow rates or heat load
- Temperature program
- Physical properties of liquids in question (if not water)
- Desired working pressure
- Maximum permitted pressure drop

FM Dimensions (measurements in mm)

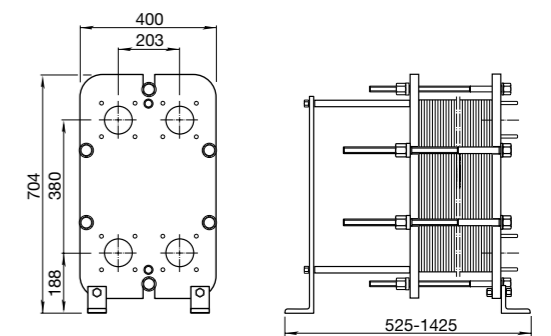

FG Dimensions (measurements in mm)

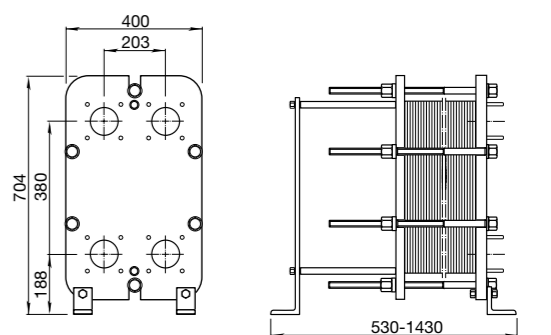

FD Dimensions (measurements in mm)

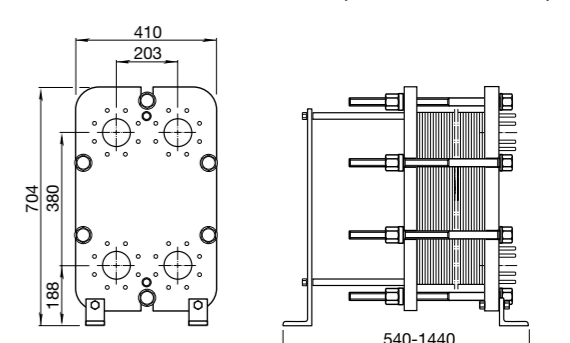

TS20

Applications

General heating and cooling duties. Heating by means of steam.

Liquid flow rate

Up to 190 kg/s, depending on media, permitted pressure drop and temperature program.

Water heating by steam

2.5 - 15 MW at a steam condensation temperature of 150 °C
2.5 - 9 MW at a steam condensation temperature of 120 °C

Plate types

TS20M plates

Frame types

FM, FG and FS

Standard materials

Frame plate:
Mild steel, epoxy painted.

Nozzles:

Carbon steel
Metal lined: Stainless steel, Titanium

Plates:

Stainless steel AISI 316 or Titanium

Gaskets:

Nitrile, EPDM or HeatSeal F™

Connections

FM	-	Size 200 mm	DIN 2501 PN10
FG	-	Size 200 mm	DIN 2501 PN16
FG	- (ASME)	Size 8"	ANSI 150
FS	-	Size 200 mm	DIN 2501 PN25/PN40
FS	- (ASME)	Size 8"	ANSI 150/ANSI 300

Mechanical design pressure (g) / temperature

FM	-	1.0 MPa / 180 °C
FG	-	1.6 MPa / 180 °C *)
FG	- (ASME)	150 psig / 350 °F
FS	-	3.0 MPa / 160 °C
FS	- (ASME)	400 psig / 320 °F

*) Frame FG also approved for 1.2 MPa / 200 °C to allow use in steam systems without safety valves.

Maximum heat transfer surface

85 m² (910 sq. ft)

Particulars required for quotation

- Flow rates or heat load
- Temperature program

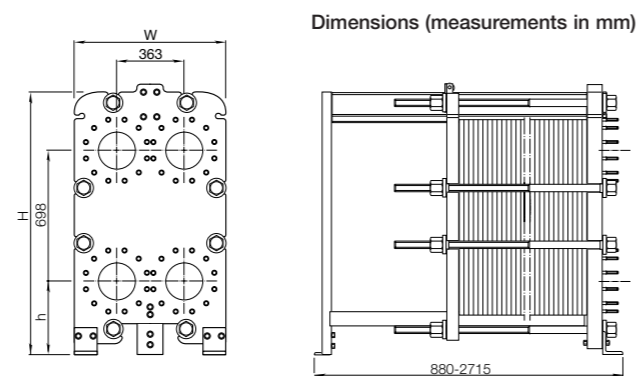

Measurements (mm)

Type	H	W	h
TS20-MFM	1405	740	360
TS20-MFG	1405	800	360
TS20-MFS	1435	800	390

- Physical properties of liquids in question (if not water)
- Desired working pressure
- Maximum permitted pressure drop
- Available steam pressure

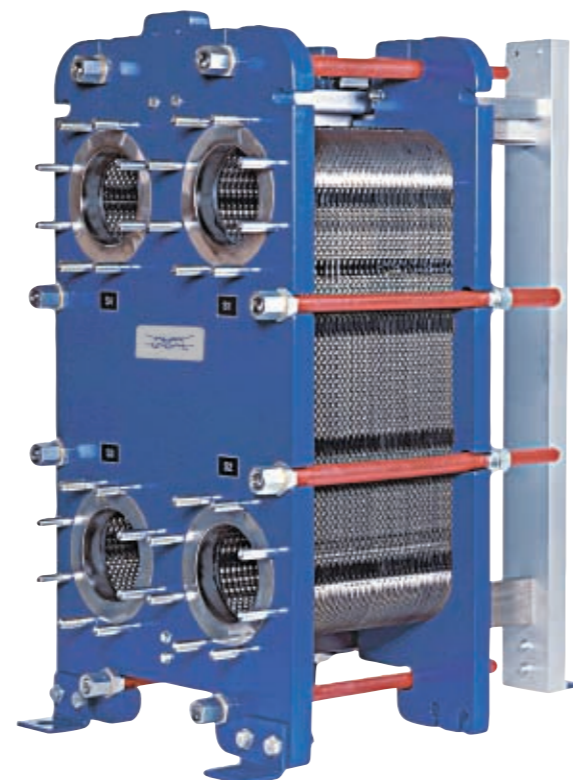

Alfa Laval in brief

Alfa Laval is a leading global provider of specialized products and engineering solutions.

Our equipment, systems and services are dedicated to assisting customers in optimizing the performance of their processes. Time and time again.

We help our customers to heat, cool, separate and transport products such as oil, water, chemicals, beverages, foodstuff, starch and pharmaceuticals.

Our worldwide organization works closely with customers in almost 100 countries to help them stay ahead.

How to contact Alfa Laval

Contact details for all countries are continually updated on our website. Please visit www.alfalaval.com to access the information.

